



SM-05 Hybrid LED Street Light

Product Description

SM-05 Hybrid LED Street Light is in an off-grid hybrid outdoor led lighting system that eliminates the reliance on power grids that conventional street lighting systems have. SM-05 Hybrid LED Street Lights are not only able to generate power from solar energy in the daytime, but also generates the power from wind. These SM-05 Hybrid LED Street Lights are very cost effective and really easy to install. It will be configured according to the environmental conditions of the installation site as well as your specific requirements. The lighting from SM-05 Hybrid LED Street Lights System lasts more than 10 hours per night, that's why demand for this product is really high due to both its effectiveness and efficiency.

Benefits of Hybrid LED Street Light:

1. Solar wind hybrid lighting system is an off-grid outdoor lighting system that is cost effective and simple to install almost anywhere with good sunshine and wind condition
2. Environment-friendly, energy-saving, long lifespan.
3. Easy installation, Free-maintenance
4. Low-voltage, safe and reliable
5. Water proof of IP65, avoid water vapor or corrosive gas erosion of chips and circuit boards.
6. Competitive for its outstanding working ability against harsh environments such as heavy rain, low temperature, and so on.



Zhejiang Seming Electronic Co., Ltd



Detailed Parameters:

No	Item	Picture	Parameters
1	SM-05 Led Lamp		Power:20w/30w/40w/50w/60w/80w/100w Chip: Philips/ Bridgelux/Cree/ Epistar Lumens:90lm/w Voltage:DC12V/24V Color temperature:3000-6500K
2	Solar Panels		Power:40w/60w/2*40w/2*50w /2*60w/2*80w/2*100w Nominal Voltage:18V Efficiency of solar cells:18% Material: Mono Cells/Poly Cells
3	Battery		Capacity:38AH/65AH/2*38AH/2*50AH/2*65AH/ 2*90AH/2*100AH Type: lead-acid Nominal Voltage:12V/24V
4	Battery Box		Material: Plastics IP Rating:IP67
5	Controll er		Rated Current:5A/10A/15A/20A Nominal Voltage:12V/24V
6	Pole		Height: 5m(A); Diameter: 90/140mm(d/D); Thickness: 3.5mm(B);Flange Plate:240*12mm(W*T)

Address: Haicheng Road, Baiguan Industrial District, Shangyu Area, Shaoxing City, Zhejiang province, China; Tel: +861 8267537265, **WhatsApp: +8618267537265**; **Email: sales@seminglighting.com**



Zhejiang Seming Electronic Co., Ltd

			<p>Height: 6m(A); Diameter: 100/150mm(d/D); Thickness: 3.5mm(B); Flange Plate: 260*12mm(W*T)</p> <p>Height: 7m(A); Diameter: 100/160mm(d/D); Thickness: 4mm(B); Flange Plate: 280*14mm(W*T)</p> <p>Height: 8m(A); Diameter: 100/170mm(d/D); Thickness: 4mm(B); Flange Plate: 300*14mm(W*T)</p> <p>Height: 9m(A); Diameter: 100/180mm(d/D); Thickness: 4.5mm(B); Flange Plate: 350*16mm(W*T)</p> <p>Height: 10m(A); Diameter: 110/200mm(d/D); Thickness: 5mm(B); Flange Plate: 400*18mm(W*T)</p>
7	Anchor Bolt		4-M16; 4-M18; 4-M20
8	Cables		18m/21m/24.6m/28.5m /32.4m/36m/
9	Wind Turbine		<p>100w wind turbine for 20w/30w/40w led lamp.</p> <p>Rated Voltage: 12/24V</p> <p>Packing Size: 470*410*330mm</p> <p>Security Wind Speed: 35m/s</p> <p>Weight: 14Kg</p> <p>300w wind turbine for 50w/60w/80w/100w led lamp.</p> <p>Rated Voltage: 12/24V</p> <p>Security Wind Speed: 35m/s</p>



Zhejiang Seming Electronic Co., Ltd

			G.W:18Kg
--	--	--	----------

Product Display:

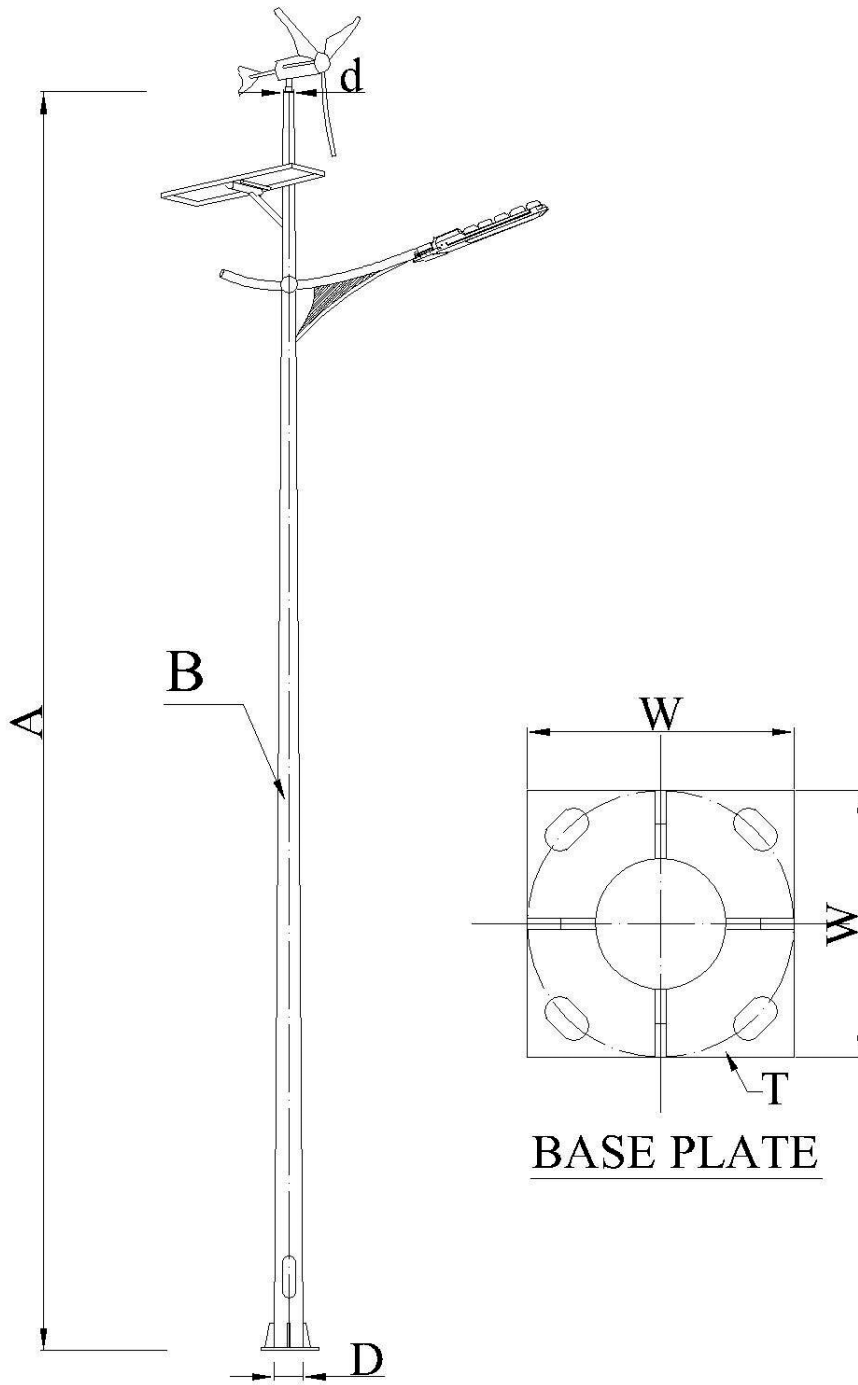

Address: Haicheng Road, Baiguan Industrial District, Shangyu Area, Shaoxing City, Zhejiang province, China; Tel: +861 8267537265, **WhatsApp: +8618267537265; Email: sales@seminglighting.com**

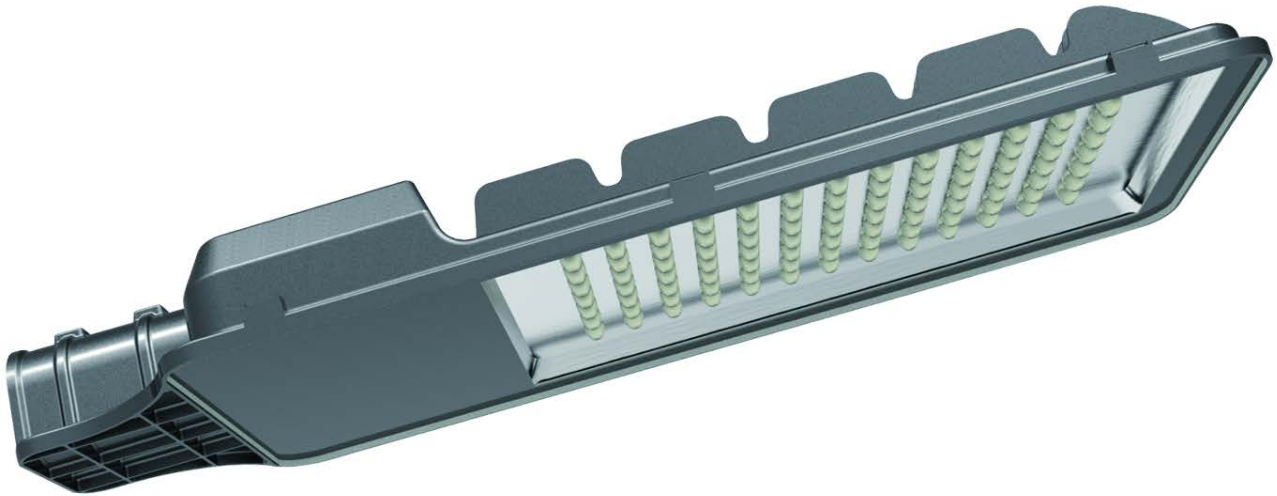



Zhejiang Seming Electronic Co., Ltd



Address: Haicheng Road, Baiguan Industrial District, Shangyu Area, Shaoxing City, Zhejiang province, China; Tel: +861 8267537265, **WhatsApp: +8618267537265; Email: sales@seminglighting.com**



Zhejiang Seming Electronic Co., Ltd

Application:

Install the product in place with good sunshine and wind condition to display the function of the product